

Valvola overcenter, versione a cartuccia, cavità SAE 08
Overcenter valve, cartridge version, SAE 08 cavity

Rev.01-2010/02

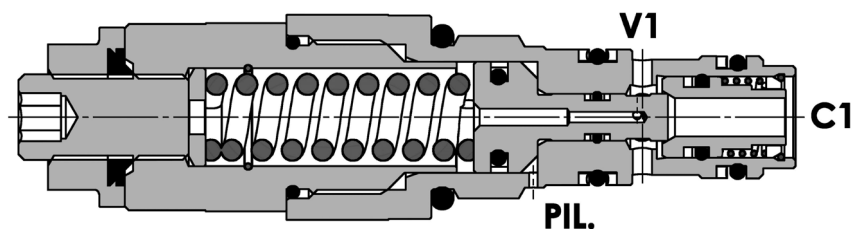
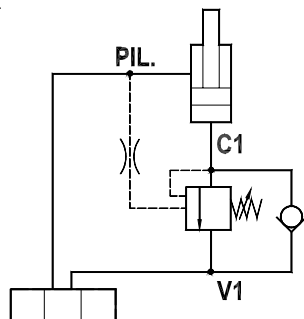

SPECIFICHE TECNICHE

Materiali: corpo in acciaio protetto da zincatura. Componenti interni in acciaio trattato termicamente.

Portata max.: fino a 25 l/min

Taratura max.: 350 bar

Regolazione pressione: mediante vite

Campo di regolazione pressione: vedere pag.02

TECHNICAL SPECIFICATIONS

Materials: body is steel made. Internal parts are in hardened steel. External surface: zinc plated.

Rated flow: up to 25 l/min

Max. setting: 350 bar

Adjustment means: leakproof screw adjustment

Adjustable pressure range: see pag.02

DIAGRAMMA PERDITE DI CARICO - PRESSURE DROP CURVES

Viscosità olio 24 mm²/sec. (3,5 °E)
 Temperatura 50 °C

Oil viscosity 24 mm²/sec. (3,5 °E)
 Temperature 50 °C

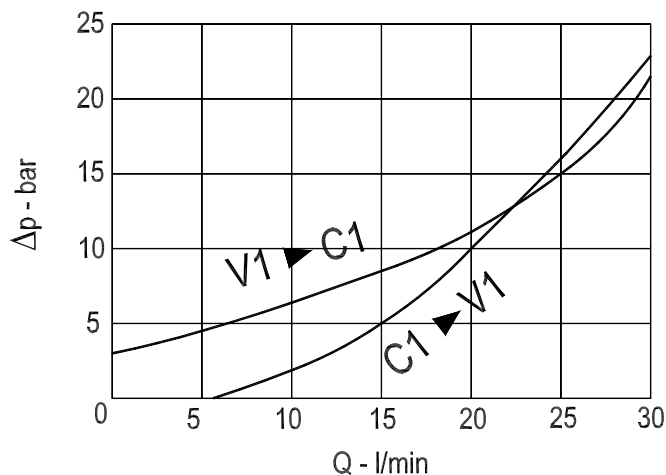



Valvola overcenter, versione a cartuccia, cavità SAE 08
Overcenter valve, cartridge version, SAE 08 cavity

Rev.01-2010/02

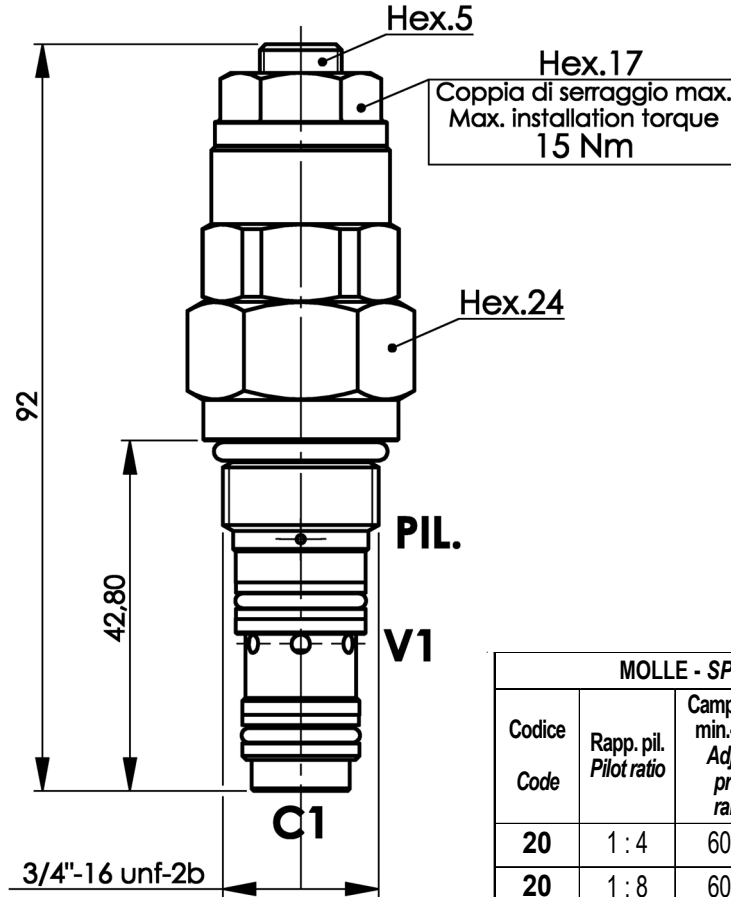

MOLLE - SPRINGS				*
Codice Code	Rapp. pil. Pilot ratio	Campo taratura min.-max. bar Adjustable pressure range bar	Increment. press. bar/giro vite Pressure increase bar/turn	Taratura standard bar Standard setting bar
20	1 : 4	60 - 220	50	170
20	1 : 8	60 - 220	50	170
35	1 : 4	100 - 350	110	280
35	1 : 8	100 - 350	110	280

TIPO TYPE	RAPP. DI PILOTAGGIO PILOT RATIO	CAVITA' CAVITY	COPPIA DI SERRAGGIO INSTALLATION TORQUE	PESO WEIGHT
			Nm	Kg
FPO 25 C	1 : 4 (standard) - 1 : 8	33082	50 - 55	0.168

ESEMPIO DI ORDINAZIONE - ORDERING CODE EXAMPLE

F P O **2 5** **C** **3 5** **B** *****

* "20" / "35":
Campi di taratura pressione - Adjustable pressure

Rapporto di pilotaggio - Pilot ratio
* Omettere se standard - Omit if standard
B = 1 : 8

Guarnizioni - Seals:
V=Viton *
Omettere se BUNA-N - Omit if BUNA-N